

ALTA ROBBINS



THE DIFFERENCE IS IN THE SEAT

Robbins Aviation pioneered the concept of a large, durable, and fully contained soft seat. This rugged seat design enables our valves to be used in a wide range of applications for extended periods of time with zero leakage.

The Alta Robbins difference begins with a large soft seat which is pressed into the cup of the bonnet assembly. The bonnet assembly is then threaded into the valve body resulting in complete containment of the seat. Metering is produced as the stem tip moves up and down through the seat orifice. Bubble tight shutoff is achieved with very low torque as the flat of the stem meets with the top of the seat.

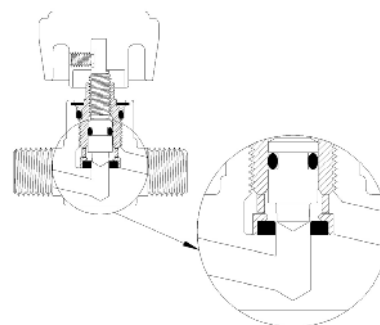
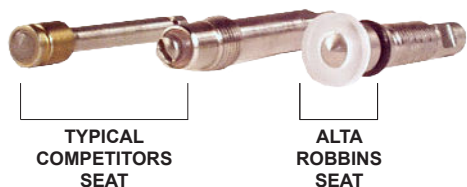

SIMPLE TO SERVICE

All functional parts can be removed for cleaning or replacement using standard tools and without disturbing body connections.

DESIGNED FOR USE ON SAMPLE CYLINDERS

- Extensively field tested by the oil refining industry in sample cylinder use and laboratory applications.
- Three piece design allows pressure to be introduced gradually.
- Bonnet safety lock nut and stem design prevent blowout or accidental unscrewing of bonnet.
- Small envelope and rugged construction permit more diversified usage than most control and shutoff valves.
- Available with rupture discs, dip tubes, and a wide variety of materials, O-rings, seats, coatings, and accessories.
- Bubble-tight shutoff with fingertip effort.
- Extra large orifice and flow passage.
- Handle skirt protects stem threads from dirt and damage.



314 SERIES

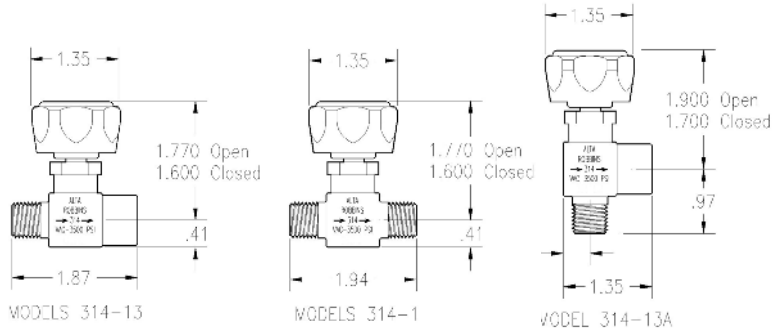

Technical Data

OPERATING PRESSURE: VACUUM-3500 PSI
SAFETY FACTOR: 4:1
INTERNAL & EXTERNAL LEAKAGE: Zero
ORIFICE DIAMETER: 0.187 Inch
C_v: 0.31
HANDLE TURNS TO OPEN: 5 (Approximate)
WEIGHT: .36 lbs. max.
OPERATING TEMPERATURE: -40°F to +250°F*

*Consult factory if your operating temperature falls outside the standard range. Optional soft goods may be available to meet your specifications.

Ordering Info

MODEL NUMBER**	INLET PORT	OUTLET PORT
314-1	1/4" NPT Male	1/4" NPT Male
314-1-4D	1/4" NPT Male	1/4" Tube Fitting
314-4D-4D	1/4" Tube Fitting	1/4" Tube Fitting
314-10	3/8" NPT Male	3/8" NPT Male
314-13	1/4" NPT Male	1/4" NPT Female
314-13A	1/4" NPT Male (Angle)	1/4" NPT Female

**NOTE: The above models ship with Buna-N O-rings, PCTFE (Kel-F) Seats (without metal insert), black handles, and 303 stainless steel bodies, bonnets, and stems. The above models do not include dip tubes or rupture discs. To change the standard configuration see *options* section on page 4.

RUPTURE DISCS

- Rupture disc valves provide a reliable method of over-pressure protection for sample cylinders and systems.
- Rupture discs are easily replaced or switched to change the burst pressure.
- The rupture disc holder is threaded into an integral port in the valve body and seals the rupture disc against the body utilizing a PTFE washer.
- All Alta Robbins 314 Series accessories and options may be added to Rupture Disc valves.

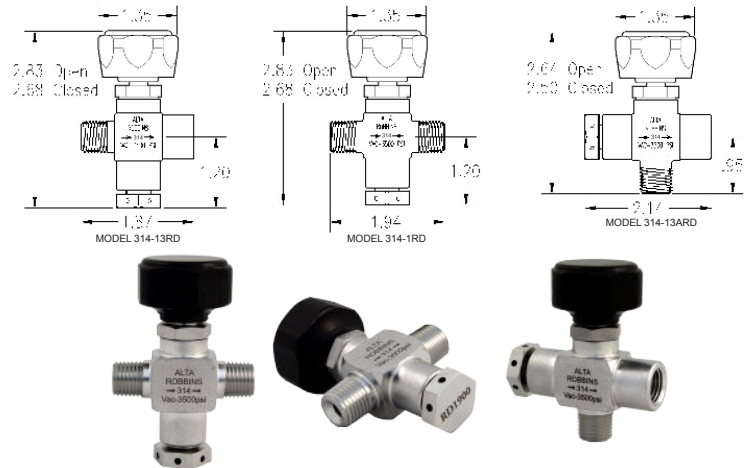

Rupture Disc Assemblies

The nominal rupture disc burst pressure should be at least 40% higher than the system operating pressure. Rupture disc burst pressure will be reduced by pulsating pressures, elevated temperature, and internal or external corrosion. In corrosive applications, regular inspections or pressure tests are necessary.

Use of this rupture disc in vacuum or alternating vacuum/pressure applications may cause premature disc failure. When vented, the rupture unit presents a potential danger caused by noise and escaping pressure, chemicals or fragmented particles.

The complete Rupture Disc Assembly consists of the disc, washer & holder. Each holder is etched with the nominal burst pressure and each disc is color coded for identification.

Ordering Info

*** To order rupture disc valves add the following suffix to the Model #

-RD**** (**** = nominal burst pressure) Ex. 314-1-RD1900

NOMINAL BURST PRESSURE	MATERIAL*	COLOR CODE
500 PSI	Aluminum	Blue
1000 PSI	316SS	Red
1500 PSI	316SS	Yellow
1900 PSI	316SS	Green
2850 PSI	316SS	Black

* Monel valves ship with monel rupture discs

Replacement Rupture Disc

To order replacement rupture discs use the following Model #

RD**** (**** = nominal burst pressure) Ex. RD1000



DIP TUBES

Purpose

Dip tubes provide a vapor space in cylinders containing liquefied gases, allowing the liquid in the cylinder to safely expand if the temperature increases. Without sufficient vapor space, a minimal temperature increase can cause the liquid to expand and dramatically increase the internal pressure of the cylinder. Typical applications require a 20% vapor space. Refer to local regulations and other appropriate guidelines for safe maximum fill densities for your application.

Dip tubes can be added to any Alta Robbins 314 Series Valve.

- Made from stainless steel or monel; other materials available upon request.
- Standard lengths of 2" and 3.75" or made to order lengths available.
- Forms an integral part of the valve.
- Valve body marked "Outage Tube" for identification.

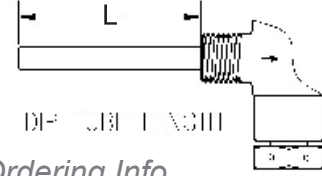

Ordering Info

To order dip tubes, add the following suffixes to the model #

2" dip tube	-2E
3.75" dip tube	-3.75E
Custom dip tube length "L" = Length in inches	-"L"E

COATINGS

SilcoNert 2000 and Silcolloy 1000 (Corrosion Resistant) coatings by SilkoTek available from stock.

- Other coatings available upon request.
- All wetted surfaces are coated.

Ordering Info

To order coating, add the following suffixes to the model #

SilcoNert 2000	-SN2
Silcolloy 1000 (Corrosion Resistant)	-SN1



HIGH PRESSURE

All Alta Robbins 314 series valves are available in a high pressure configuration.

- Increases Max Operating Pressure from 3500 psi to 5000 psi.

Ordering Info

To order any 314 series valve in a high pressure configuration, add the following suffix to the model #

High Pressure(5000 psi)	-HP
-------------------------	-----



ACCESSORIES

Rupture Disc Tees

Ordering Info

To order Rupture Disc Tees use the following Model #

RDT-**** (**** = nominal burst pressure)

Ex. RDT-2850

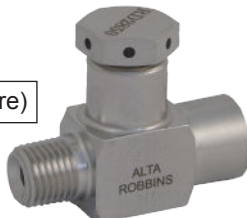

Dip Tube Adaptors

Ordering Info

To order Dip Tube Adaptors use the following Model #'s

2" dip tube	DTA-2E
3.75" dip tube	DTA-3.75E
Custom dip tube length "L" = Length in inches	DTA-"L"E



OPTIONS

Standard

All 314 Series Valves come standard with Buna-N O-rings, PCTFE (Kel-F) seats, black handles and 303 Stainless Steel; however, a wide selection of materials are available for your specific use. See below. If chemical compatibility and operating temperature range questions arise, please consult factory or Dupont Chemical Resistance Guide.

Handles

- Machined from solid 6061 aluminum, anodized to color with incorporated mild knurl for operator's comfort.
- Custom colors and engravings available upon request.

Optional handle colors

To order add the following suffixes to the model #

- Red -R
- Blue -B
- Green -G
- Purple -P
- Gold -GD
- Silver -S
- Bronze -BR

Contact factory for additional colors and/or engravings.

O-rings

To order optional O-rings, add the following suffixes to the Model #

- Viton -12
 - Buna-N for MTBE Service -59
 - Kalrez™ -08
 - Ethylene Propylene -06
 - Butyl -91
- Contact factory if required O-rings aren't listed

Seats

To order optional seats, add the following suffixes to the Model #

- Teflon -T
- Nylon -N
- Seat with metal insert -763

Materials

To order optional body, bonnet, and stem materials, add the following suffixes to the Model #

- 316 Stainless Steel -768
- Monel -M

REPLACEMENT PARTS

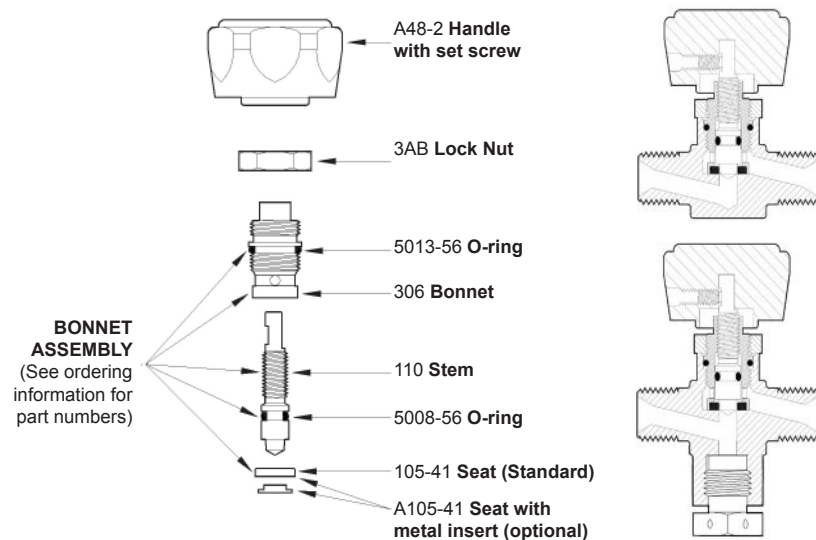

Ordering Info

See options section above for optional O-rings and materials

Bonnet Assembly

Kel-F (PCTFE) seat	KA309
Teflon seat	TA309
Nylon seat	NA309

Soft Goods Kits

Kel-F (PCTFE) seat	4018-4-1
Teflon seat	4018-1-1
Nylon seat	4018-2-1

O-Ring Installation Mandrel-Stem T-221-7

O-Ring Installation Mandrel-Bonnet T-271

ORDERING SYNTAX

To order 314 Series valves please use the syntax shown below. The Model Number is required. Only add the optional dash codes if needed. Valves come standard with Buna-N O-rings, PCTFE (Kel-F) seats, black handles, and 303 SS.

Example: 314-1-2E-R is the correct syntax for a 314-1 model (1/4" Male NPT ports) built with 303 SS, Buna-N O-rings, optional 2" dip tube and optional red handle.

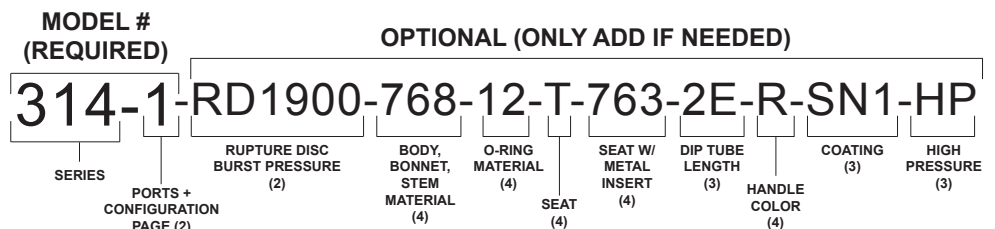

110 SOUTH 1200 WEST, LINDON UTAH 84042 · PHONE (801) 785-1114 · FAX (801) 785-4333 · WEB ALTAROBINS.COM

WARRANTY: ALTA ROBINS WARRANTS TO THE PURCHASER OF ITS PRODUCTS THAT ANY PART THEREOF WHICH PROVES TO BE DEFECTIVE IN MATERIAL OR WORKMANSHIP WITHIN ONE YEAR FROM THE DATE OF ORIGINAL PURCHASE FOR USE WILL BE REPLACED FREE OF CHARGE. THIS WARRANTY DOES NOT APPLY TO DAMAGES RESULTING FROM ACCIDENTS, ALTERATIONS, MISUSE, OR ABUSE.

NOTICE: THE DESIGNS, DATA, AND/OR PROCESSES SET FORTH HEREIN OR IN CONNECTION HERewith ARE DIRECTLY RELATED TO PRODUCTS OF ALTA ROBINS.